

Bridge Rectifier

2W10G

1000V / 1,5A

DATASHEET

OEM – General Semiconductor

Source: General Semiconductor Databook 1998

W005G THRU W10G

GLASS PASSIVATED SINGLE-PHASE BRIDGE RECTIFIER

Reverse Voltage - 50 to 1000 Volts Forward Current - 1.5 Amperes

Case Style W0G

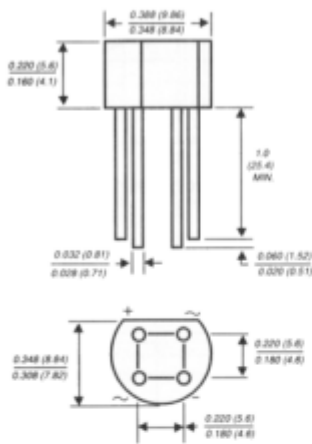

Dimensions in inches and (millimeters)

FEATURES

- ◆ Plastic material has Underwriters Laboratory Flammability Recognition 94V-0
- ◆ This series is UL listed under the Recognized Component Index, file number E54214
- ◆ Glass passivated chip junctions
- ◆ High case dielectric strength
- ◆ Typical I_R less than $0.1\mu A$
- ◆ High overload surge capability
- ◆ Ideal for printed circuit boards
- ◆ High temperature soldering guaranteed:
260°C/10 seconds, 0.375" (9.5mm) lead length, 5lbs (2.3kg) tension



MECHANICAL DATA

Case: Molded plastic body over passivated junctions
Terminals: Plated leads solderable per MIL-STD-750, Method 2026
Mounting Position: Any
Weight: 0.04 ounce, 1.1 grams

MAXIMUM RATINGS AND ELECTRICAL CHARACTERISTICS

Ratings at 25°C ambient temperature unless otherwise specified.

	SYMBOLS	W005G	W01G	W02G	W04G	W06G	W08G	W10G	UNITS
Maximum repetitive peak reverse voltage	V_{RRM}	50	100	200	400	600	800	1000	Volts
Maximum RMS voltage	V_{RMS}	35	70	140	280	420	560	700	Volts
Maximum DC blocking voltage	V_{DC}	50	100	200	400	600	800	1000	Volts
Maximum average forward rectified current at 0.375" (9.5mm) lead length at $T_A=25^\circ C$	$I_{(AV)}$	1.5							Amps
Peak forward surge current single sine-wave superimposed on rated load (JEDEC Method)	I_{FSM}	50.0							Amps
Rating for fusing (t<8.3ms)	I^2t	10.0							A ² sec
Maximum instantaneous forward voltage drop per leg at 1.0A	V_F	1.0							Volts
Maximum DC reverse current at rated $T_A=25^\circ C$ DC blocking voltage per leg $T_A=125^\circ C$	I_R	5.0 500.0							μA
Typical junction capacitance per leg (NOTE 1)	C_J	14.0							pF
Typical thermal resistance per leg (NOTE 2)	$R_{\theta JA}$ $R_{\theta JL}$	36.0 11.0							$^\circ C/W$
Operating junction temperature range	T_J	-55 to +150							$^\circ C$
Storage temperature range	T_{STG}	-55 to +150							$^\circ C$

NOTES:

- (1) Measured at 1.0 MHz and applied reverse voltage of 4.0 Volts
- (2) Thermal resistance from junction to ambient and from junction to lead at 0.375" (9.5mm) lead length P.C.B. mounting

RATINGS AND CHARACTERISTICS CURVES W005G THRU W10G

